

PlasmaFil

Art. No.: 22 230



Applications

- Medium levels of smoke and dust
- Specifically suited for plasma or flame cutting processes

Benefits

- Contamination-free dust collection due to lever fixing of the dust collection container
- Considerable energy cost savings by using the optional automatic volume control through demand-based extraction capacity regulation
- Uninterrupted continuous operation due to automatic, demand-oriented filter cleaning

Properties

- KemTex PE-M Cartridge Filter
- Automatic filter cleaning on required basis
- Highly effective and uniform filter cleaning by means of rotary nozzle
- Quick and easy installation thanks to user-friendly preparation
- Low space requirement due to compact design
- Easy to use: Intuitive & ergonomic one-button operation

Accessories

- Automatic start/stop using contact
- Automatic suction power regulation
- Spark separator – SparkTrap



Technical Data

Filter	
Filter stages	1
Filter method	Cleanable filter
Filter cleaning method	Rotating nozzle
Filter surface	15 m ²
Number filter elements	4
Filter surface total	60 m ²
Type of filter	Filter cartridge
Filter material	PE-M membrane
Filter efficiency	> 99.99 %
Dust classification	M
Basic data	
Max. fan performance	5500 m ³ /h
Extraction capacity	2750 - 3900 m ³ /h
Vacuum	2500 - 1550 Pa
Weight	559 kg
Motor power	4 kW
Power supply	3x380-415V/50Hz
Rated current	7,45 A
Noise level	72 dB(A)
Additional information	
Fan type	Radial fan
Compressed air supply	5 - 6 bar
Air outlet	355 mm
Air intake	355 mm
Capacity Dust collection container	70 l

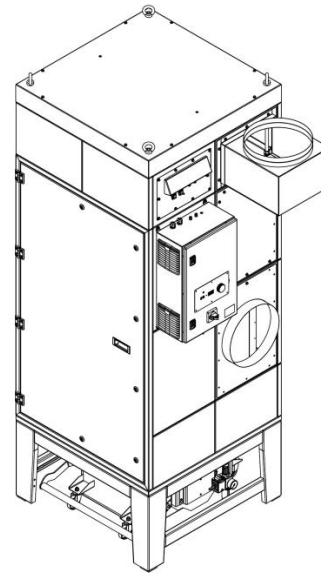
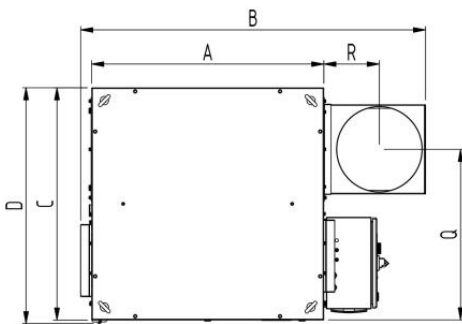
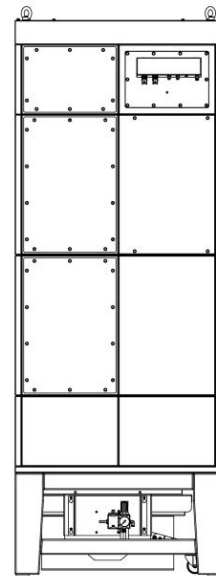
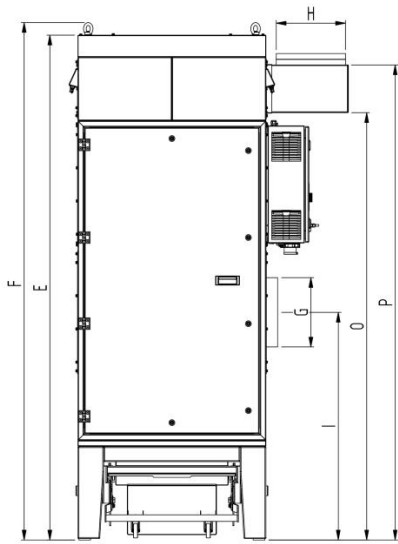

Technical Data

Dimensions

A	962 mm
B	1302 mm
C	962 mm
D	2110 mm
E	3230 mm
F	250 mm
G	1146 mm
H	1716 mm
I	706 mm
J	175 mm
K	250 mm
L	669 mm
N	293 mm
O	896 mm
P	355 mm

The shown transition pieces are optional

Pressure-volume graph

- Fan characteristic curve
- Working pressure increase
- ▨ Recommended Use

