

LaserFil

Art. No.: 27 760



Applications

- Medium levels of smoke and dust
- Specifically suited for laser cutting processes

Benefits

- Contamination-free dust collection due to lever fixing of the dust collection container
- Considerable energy cost savings by using the optional automatic volume control through demand-based extraction capacity regulation
- Uninterrupted continuous operation due to automatic, demand-oriented filter cleaning

Properties

- KemTex PE-M Cartridge Filter
- Automatic filter cleaning on required basis
- Highly effective and uniform filter cleaning by means of rotary nozzle
- Quick and easy installation thanks to user-friendly preparation
- Low space requirement due to compact design
- Easy to use: Intuitive & ergonomic one-button operation

Accessories

- Automatic start/stop using contact
- Automatic suction power regulation
- Spark separator – SparkTrap



Technical Data

Filter

Filter method	Cleanable filter
Filter cleaning method	Rotating nozzle
Filter surface	30 m ²
Number filter elements	4
Filter surface total	120 m ²
Type of filter	Filter cartridge
Filter material	PE-M membrane
Filter efficiency	> 99.9 %
Dust classification	M

Basic data

Max. fan performance	7600 m ³ /h
Extraction capacity	3800 - 5500 m ³ /h
Vacuum	3200 - 1850 Pa
Weight	605 kg
Motor power	7,5 kW
Power supply	3x380-415V/50Hz
Rated current	13,7 A
Noise level	76 dB(A)

Additional information

Fan type	Impeller, direct driven
Compressed air supply	5 - 6 bar
Air outlet	355 mm
Air intake	355 mm
Capacity Dust collection container	70 l

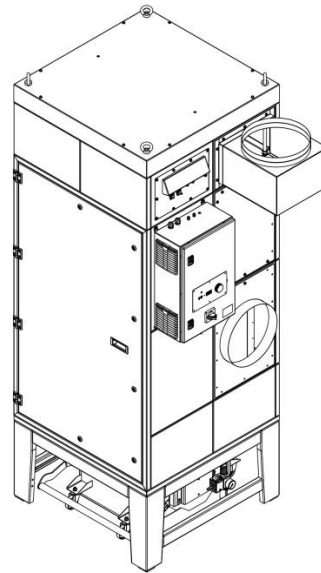
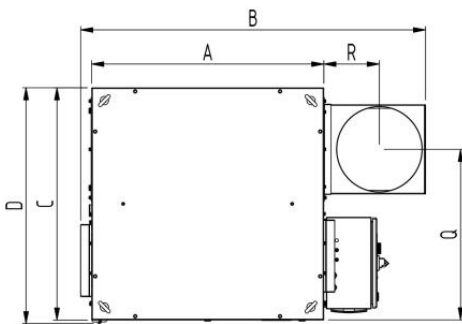
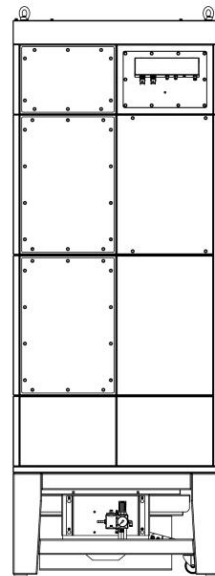
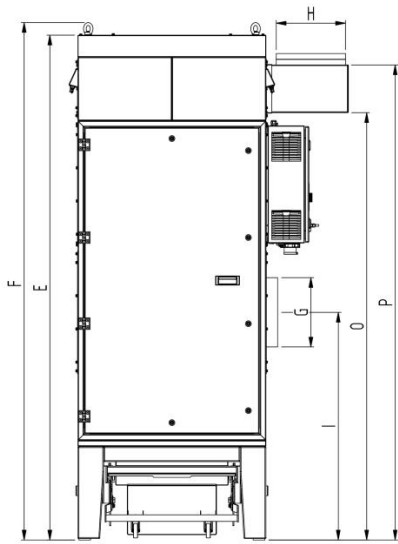

Technical Data

Dimensions

A	962 mm
B	1385 mm
C	962 mm
D	978 mm
E	2585 mm
F	2650 mm
G	355 mm
H	355 mm
I	1166 mm
O	2188 mm
P	2433 mm
Q	707 mm

The shown transition pieces are optional

Pressure-volume graph

- Fan characteristic curve
- Working pressure increase
- ▨ Recommended Use

